

**ENCHLOR** <sup>INC.</sup>

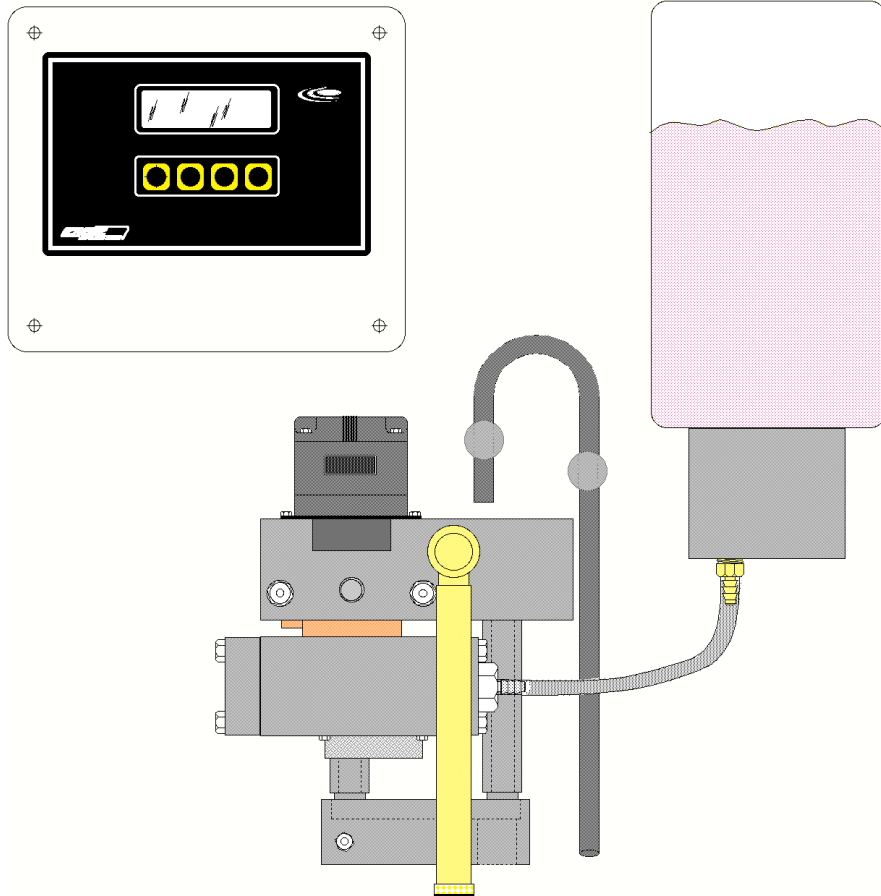

**8000  
RESIDUAL ANALYZER**

***Installation and Operation  
MANUAL***

## TABLE OF CONTENTS

I	INTRODUCTION	3
II	SPECIFICATIONS	3
III	PRINCIPAL OF OPERATION	4
	A GENERAL	4
	B REAGENT FEED SYSTEM	4
IV	INSTALLATION	5
	A WALL PANEL MOUNTING	5
	B HYDRAULIC CONNECTIONS	5
	C TERMINAL CONNECTIONS	5 (DIAGRAM)
V	REAGENTS	5
	A LIQUID REAGENTS	6
	B CARBON DIOXIDE	6
VI	START-UP	7
VII	OPERATION	7
	A CLEANING	7
	B REAGENT VALVE (STAR WHEEL)	8
	C GOLD ELECTRODE	9
	D MOTOR / STRICKER	10
	E MOTOR REPLACEMENT	10
VII	C02 BUFFERING	11
IX	TROUBLE SHOOTING	11 - 13
X	INSTRUMENT SETTINGS	13 - 18
XI	WIRING DIAGRAM	19

## I. INTRODUCTION

The 8000 Residual Analyzer/Controller is an amperometric instrument designed to continuously analyze residual levels of free or total chlorine, chlorine dioxide, or potassium permanganate in water, wastewater or liquids containing particulates.

## II. SPECIFICATIONS

Power Supply	115/230 VAC Switch selectable.
Power Consumption	12W
Display	LCD, backlit, 16 characters by 2 lines, 5mm character height, 5x8 character matrix.
Pushbuttons	Four, tactile dome.
Relays	High residual, low residual, and two spares Mechanical (AC or DC), Rating (standard) 1.2A, 125VAC resistive or optional 5A @ 250VAC
Cell	Au/Cu (Gold anode/Copper Cathode) Galvanic Cell input
Temperature	Thermistor 10k ohms @ 25C, Beta=4100
Analog Output	Isolated, 4 to 20mA, 500ohm drive. Represents $Cl_2$ residual
Digital Output	20mA Serial (transmits to remote computer)
Instrument Range:	0-0.1, 0-0.2, 0-0.3, 0-0.5, 0-1, 0-2, 0-3, 0-5, 0-10, 0-20, 0-30 mg/l field selectable
Sample Flow:	500 cc/minute: 5 psig maximum
Sample Supply:	Continuous. Where sample interruption may be required; provisions must be made to keep the electrodes wet with fresh water.
Analyzer Location:	As close as possible to the sample point to reduce lag time.

Speed of Response: 4 Seconds from sample entry to display indication. Full scale residual change 1-1/2 to 2 minutes.

Ambient Temperature Range: 35 degrees to 120 degrees F (2 degrees to 50 degrees C)

Sample Temperature Range: 35 degrees 120 degrees F (2 degrees to 50 degrees C)

Sample Limitations: Samples containing high concentrations of metal ions or certain corrosion inhibitors may effect analyzer operation.

Accuracy: +/- 2% of selected range

Electronics Enclosure: NEMA 4X

Reagent Requirements:

RESIDUAL MEASUREMENT	REAGENT REQUIREMENTS
----------------------	----------------------

Chlorine (Free)	pH buffer or CO <sub>2</sub> gas
Chlorine (Total)	pH buffer or CO <sub>2</sub> gas & potassium iodide
Chlorine Dioxide	pH buffer & potassium iodide
Potassium Permanganate	pH buffer

### III. PRINCIPAL OF OPERATION

#### A. GENERAL

A sample of liquid is delivered to the sample filtering chamber at an approximate rate of 500 cc/minute. The excess overflows to drain.

The sample then passes through the annular space between the two fixed electrodes in the sensing cell. As it passes, a small direct current is generated in direct linear proportion to the amount of chemical present in the liquid.

The surface of both electrodes is kept clean by the continuous action of PVC spheres agitated via a motor driven rotating striker.

This constant cleaning eliminates signal drift and recalibration providing an accurate residual measurement. A thermistor compensates for sample temperature variations.

The residual value is displayed on the LCD display.

**B. REAGENT FEED SYSTEM**

Reagents are fed into the sensing cell to lower the pH to enable reliable measurement. The sample pH is adjusted by the buffer to a range of 4.0 to 4.5 pH. When CO<sub>2</sub> is used as a buffer, the pH will be lowered to a range of 5.5 to 6.0 pH. The addition of potassium iodide, when used, reacts to liberate free iodine and provides a means of measurement of total chlorine residual. Refer to CO<sub>2</sub> BUFFERING on page 9 for CO<sub>2</sub> operation.

**IV. INSTALLATION**

**A. WALL PANEL MOUNTING**

1. Position the analyzer panel on a wall at eye level and as close as possible to the sample source. Secure with bolts, leveling the analyzer before securing.

**B. HYDRAULIC CONNECTIONS**

1. Connect the necessary length of drain hose to the drain outlet on the analyzer. Secure with a hose clamp. Route hose to maintain a gravity fed drain (downward slope).
2. Connect one end of the 3/8" sample supply tubing to the source using a suitable connection (customer supplied). Route tubing to the sample filter chamber through the tubing holders on the analyzer panel. Position the end of the tubing between the filter chamber and below the top of the overflow weir.

### C. TERMINAL CONNECTIONS

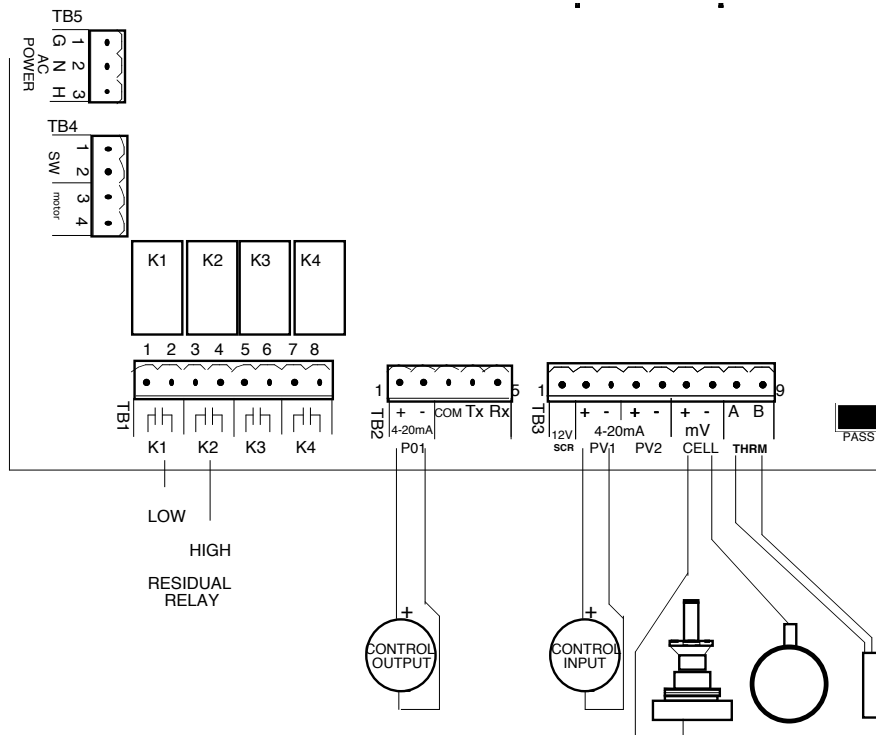

**NOTE:** ALL WIRING MUST COMPLY WITH APPLICABLE LOCAL AND NATIONAL ELECTRICAL CODES.

1. Remove four (4) screws securing side cover and remove cover.
2. Connect input power (120 Vac standard) to N,H,G terminals.
3. Connect current output and alarm contacts.

**NOTE:** DO NOT RUN LINE VOLTAGE AND SIGNAL VOLTAGE IN THE SAME CONDUIT.

### V. REAGENTS

A pH buffering solution or carbon dioxide gas is required for analyzer operation. In addition, potassium iodide solution is required when measuring other residuals as described in the SPECIFICATIONS Section.

Fill reagent bottle with pre-mixed solution or mix reagents as follows:

**NOTE:** NEVER DISABLE UNIT WITHOUT REMOVING REAGENT BOTTLE AND FLUSHING WITH CLEAN WATER UNTIL THE ENTIRE CHEMICAL IS REMOVED.

A. Liquid Reagents for Chlorine Residual

Pre-mixed pH buffer solution is available, contact factory. OR, mix pH buffer solution as follows:

1. For Free Chlorine Measurement:

- a. Using a 1 gallon (3.8-liter) bottle, fill bottle 1/2 full with distilled/deionized water.
- b. Add 920 grams sodium acetate trihydrate crystals and mix until all the crystals are dissolved.
- c. Add 1800 grams or 1730 cc glacial acetic acid or distilled white vinegar.
- d. Fill bottle to the top with distilled or deionized water and shake to thoroughly mix solution. Pour contents into the analyzer reagent bottle.

2. For Total Chlorine Measurement:

Mix potassium iodide solution in a separate bottle. (Potassium iodide crystals are available. Contact factory.)

- a. Follow Steps 1.a. through 1.d. above.
- b. Add potassium iodide crystals as follows:  
ANALYZER RANGE  
10 grams for 0.5 mg/l  
40 grams for 2.0 mg/l  
60 grams for 3.0 mg/l  
100 grams for 5.0 mg/l  
200 grams for 10, 20 & 30 mg/l
- c. Shake until crystals are completely dissolved.

- d. Fill bottle to the top with distilled/deionized water; shake again. Pour contents into the reagent bottle through a fine strainer. The bottle will provide approximately a one week supply of reagent.

B. Carbon Dioxide Gas

When using carbon dioxide for pH buffering, a carbon dioxide gas flow rate of 200 cc per minute is required. For free chlorine measurement, carbon dioxide is used alone, and replaces the liquid buffer . When measuring total chlorine using carbon dioxide, it is necessary to add potassium iodide solution in the quantities listed above, 2.b., to de-ionized water alone.

**NOTE:** For Chlorine Dioxide and Potassium Permanganate consult factory.

**VI. START-UP**

- A. Hold filled reagent bottle upright and pull the tapered plug upward until the hole in cap is plugged. Turn bottle upside down and install into reagent feeder body. The weight of the reagent bottle opens the tapered plug and the bottle will rest on the o-ring on top of the feeder body.
- B. Start water sample flow at approximately 500 cc/minute . To drain, water must be flowing over the overflow weir in the sample filter chamber.

The sample must be supplied continuously for reliable operation. If the system requires occasional sample cutoff, provisions must be made to keep the electrodes wet.

Sampling from a pressurized source may require a pressure regulating valve to hold the flow constant. Maximum desired pressure: 5 psig (0.3 bar).

If sampling from sewage, a flushing “Y” strainer is necessary to prevent sample line from plugging. Other types of filters are not recommended.

- C. Turn the power on to the analyzer.

- D. If air bubbles are present in the reagent or flow tubing, remove by squeezing or tapping tubing or disconnecting tubing at the analyzer and flushing momentarily.
- E. The analyzer requires a minimum stabilization time of 24 hours. During this time, reagents must be feeding into the cell . Under normal circumstances, reagent level will drop approximately 1" per 24 hrs.
- F. After stabilization, calibration may be required. Instruments are calibrated at the factory; at start-up Auto Zero adjustment is necessary to compensate for composition of the local water.

## VII. OPERATION

### A. CLEANING

The frequency of cleaning the analyzer is greatly affected by the condition of the water. By visually inspecting for dirt built-up, determine the need for cleaning. The following points should be cleaned as indicated:

1. The inlet filter screen and overflow weir should be cleaned when a dirt build-up is observed or when the screen has been plugged sufficiently to stop flow.

Lift out the overflow weir and filter screen. Hold parts under a water stream until clean and reinstall in the analyzer.

2. If the analyzer becomes clogged to the point where no water is passing over the overflow weir, the analyzer must be flushed. The overflow can be observed below the motor or by the overflow tube directly behind the cell for flow into the drain block. Flush as follows:
  - a. Turn the power switch to the OFF position.
  - b. Remove the flush plug in the flow tube with sample flowing and allow to drain.
  - c. Install flush plug into flow tube.
  - d. Repeat step b (steps b and c can be repeated until the unit is clean).

- e. Turn the power switch to the ON position and resume operation.

B. REAGENT VALVE

If the reagent feed has stopped and all air is removed from tubing, the reagent valve (P/N 450044) must be cleaned. The feed rate of this valve is very small, therefore, be certain the reagent has stopped before cleaning is attempted. Check for feed by marking the reagent level on the bottle and observing the change in level over eight (8) hours. If the reagent level has not lowered during this test, the valve must be cleaned. Proceed as follows:

1. Turn the power switch to the OFF position.
2. Stop sample flow.
3. Lift and rotate clip securing the reagent bottle. Raise reagent bottle approximately 2" and pull down on the valve stem until the hole in the cap is plugged. Remove reagent bottle.
4. Hold reagent bottle upright, unscrew and remove cap. Place open bottle close to clear tubing connector at adaptor. Carefully unscrew connector nut releasing clear tube and drain remaining reagent from the reservoir into the reagent bottle. Screw cap onto reagent bottle.
5. Remove flush plug to drain unit. After the analyzer is completely drained, replace plug.
6. Loosen the four (4) screws securing the adaptor and remove adaptor and o-ring.
7. Clean out bottom body if necessary.
8. The adaptor provides mounting for reagent valve components. This valve consists of a starwheel, bushing, pin, o-ring, spring clip and a screw. Loosen the screw and rotate the spring 180 degrees. Pull up on the starwheel to release the pin from bushing. DO NOT remove bushing or o-ring. Clean all parts under a stream of water. If the 1/16" diameter holes in the starwheel and bushing are clogged, use a straight pin to

remove the obstruction. DO NOT scratch the mating surfaces or damage the edge of the hole. Place starwheel and pin into bushing. Turn the spring clip back 180 degrees to apply force to the pin. Secure screw.

9. Place large o-ring into groove and replace adaptor. Secure, using four (4) screws.
10. Reconnect clear tubing to connector and secure nut.
11. Invert reagent bottle on reservoir and secure using clip provided.
12. Begin sample flow as described under START-UP.
13. Turn power switch to the ON position. If air bubbles appear in the clear reagent tubing, remove as described in START-UP.

#### C. GOLD ELECTRODE

Normal life of the gold electrode is three to five years. This can vary depending upon chemical residual and the quality of water. The gold electrode should appear clean and shiny.

**NOTE:** THE MEASURING CELL ASSEMBLY RETAINS 200 -  $\frac{3}{16}$ " DIAMETER PVC SPHERES WITHIN THE TOP BODY OF THE ANALYZER. WHEN THIS ASSEMBLY IS WITHDRAWN, THESE SPHERES WILL DROP OUT.

1. Refer to OPERATION, Section B and proceed with Steps 1 through 7. Remove the adapter and all reagent.
2. Disconnect the wire from the gold electrode assembly.
3. While holding a bucket under the analyzer, unscrew the gold electrode by hand. As the assembly is withdrawn, the spheres will begin dropping out. Hold the bucket below until all the spheres are removed. Remove large o-ring on the electrode assembly.
4. Inspect the condition of the gold electrode. Clean and polish with water and clean cloth. If electrode is damaged, replace.

5. Place large o-ring in groove on new electrode assembly and screw the assembly into the bottom body, by hand, until snug.
6. Reconnect wire to the gold electrode assembly.
7. Remove the plug located in the analyzer top body. Deposit all spheres through the hole provided and replace plug.
8. After spheres have been deposited, rotate motor/striker assembly by hand, checking for rubbing. The striker can be observed below the motor. If the striker is not rotating, refer below to Section D, MOTOR/STRIKER ASSEMBLY. Turn power switch to the ON position.

#### D. MOTOR/STRIKER ASSEMBLY

Replacing the motor (Part #450039) or striker assembly (Part #450045) can be performed more easily if the main analyzer assembly is removed from the panel and taken to a table or flat surface.

1. Disconnect power to the analyzer motor.
2. Disconnect signal wires from the copper and gold electrodes.
3. Remove reagent from the feeder body and reagent tubing from valve adaptor. Unscrew two screws holding the main assembly to the panel. Place the main assembly on a table.
4. With the main assembly upright, remove the three (3) screws holding the motor plate to the top body. Lift the motor straight up and out of the top body.
5. Invert the analyzer assembly and dump the 200 spheres into a container. Remove the valve adaptor. The main assembly is now disassembled as far as required.

#### E. MOTOR REPLACEMENT

1. If the motor is to be replaced, remove the striker from the motor shaft. Install on new motor after turning the center set screw out approximately two (2) turns.

2. Turn the side set screw in striker until it contacts the motor shaft. The striker should be capable of sliding onto the motor shaft when force is applied.
3. Fit the striker on to the motor so a small space is between the top of the striker and the motor plate. Insert motor/striker assembly into the main analyzer assembly by pushing on the motor until the motor plate is seated on the top body.
4. Carefully remove the motor/striker from the main assembly. Lightly tighten the side set screw in the striker. Turn in center set screw until contact is made with the motor shaft. Now, back out center set screw  $\frac{1}{8}$  to  $\frac{1}{4}$  turn. Loosen side striker set screw and push up on the motor shaft. Retighten side set screw snugly. Reinstall the motor/striker assembly with the three (3) motor screws.
5. Rotate the motor/striker assembly by hand checking for drag or rubbing. The motor should turn freely by hand.
6. Insert the 200 PVC spheres and rotate motor/striker again, feeling for drag or rough spots. If drag is present, repeat Steps 2 through 5 for adjusting the striker.
7. Reassemble to panel by reversing MOTOR/STRIKER ASSEMBLY 1, 2 and 3.

## VIII. CO<sub>2</sub> BUFFERING

- A. The CO<sub>2</sub> diffuser replaces the pH4 buffer solution starwheel on the right side of the analyzer. The CO<sub>2</sub> diffuser may be placed on either side. For total chlorine residual, the CO<sub>2</sub> diffuser is placed on the left side of the bottom body in place of the adaptor. Solution fed by the starwheel assembly on the right side must be potassium iodide solution only.
- B. Locate the vent tube over the analyzer drain.
- C. Adjust regulator and rate valve to obtain a flow of about 0.25 ppd (44 ccm) of CO<sub>2</sub> and check for gas leaks with soap solution. Check all tubing connections at cylinder, regulator and analyzer and repair any leaks.

- D. Set flow rate of CO<sub>2</sub> initially at 1 ppd (175 ccm). The actual flow rate may be adjusted. A constant pH should be maintained.
- E. CO<sub>2</sub> gas will buffer the sample water to maintain the pH level between 5 and 6. Calibration of the analyzer is unchanged.

**CAUTION: Remember to turn off the CO<sub>2</sub> cylinder anytime the analyzer is shut down.**

**IX. TROUBLESHOOTING CHART**

**NOTES:**

- A. Verify sample flow at the analyzer intake between the overflow weir and the filter screen (500 cc/minute )1 pint/minute) at 5 psig (0.3 bar). Verify constant sample flow through the analyzer by observing flow at the drains. **SAMPLE MUST ALWAYS FLOW TO THE ANALYZER.**
- B. Verify analyzer motor connection to proper power supply and operating.
- C. Verify reagent feed to the analyzer. Let the analyzer run for 24 hours and measure reagent usage (normal 3/4" to 1-1/8" change in level).

**TROUBLE:** **Excessively high or low output signal.**

- PROBABLE CAUSE:**
- 1. Air bound sample or reagent line.
  - 2. Dirty or worn electrode.
  - 3. Damaged thermistor.

- CORRECTIVE ACTION:**
- 1. Check drain tubing for sample flow. For inadequate flow from left drain, tap base of low tubing to release trapped air bubbles.
  - 2. See OPERATION, Section C. Remove, clean, and/or replace gold electrode.
  - 3, Test and replace thermistor. See OPERATION, Section F.

**TROUBLE:** **Output reacts slowly to residual change.**

- PROBABLE CAUSE:**
- 1. Coating on measuring cell.
  - 2. Excessive amounts of suspended solids.
  - 3. Nonrepresentative sample.

- CORRECTIVE ACTION:**
- 1. Clean electrode.
  - 2. Filter sample.

- 3. Relocate sample point.

- TROUBLE:** **Motor operation noisy, erratic, no motion.**  
**PROBABLE CAUSE:**
  1. Motor wired incorrectly.
  2. Misaligned striker has PVC spheres jammed.
  3. Faulty motor.
- CORRECTIVE ACTION:**
  1. Rewire per label.
  2. Adjust striker assembly. See OPERATION, Section D. Check plug is tight in top body.
  3. Replace motor. See OPERATION, Section G.
- TROUBLE:** **Inadequate span adjustment.**  
**PROBABLE CAUSE:**
  1. Coating on measuring cell.
  2. Solids in measuring cell.
- CORRECTIVE ACTION:**
  1. Clean electrode. See OPERATION, Section C.
  2. Filter sample.
- TROUBLE:** **Inability to zero.**  
**PROBABLE CAUSE:**
  1. Residual present in sample.
- CORRECTIVE ACTION:**
  1. Use de-chlorinated water.
- TROUBLE:** **Improper reagent feed.**  
**PROBABLE CAUSE:**
  1. Faulty starwheel.
- CORRECTIVE ACTION:**
  1. See OPERATION, Section B.
- TROUBLE:** **Excessive reagent feed.**  
**PROBABLE CAUSE:**
  1. Striker motor rotation reversed.
  2. At shutdown, starwheel aligned for constant reagent feed.
- CORRECTIVE ACTION:**
  1. Motor must turn counterclockwise, (top view). Inspect motor leads for proper connection.
  2. Jog motor to reposition starwheel.
- TROUBLE:** **Insufficient reagent feed.**  
**PROBABLE CAUSE:**
  1. Starwheel plugged.
  2. Blockage in feed line to the starwheel.
- CORRECTIVE ACTION:**
  1. Clean. See OPERATION, Section B.
  2. Check per OPERATION, Section B.

- TROUBLE:** **Display blank.**
- PROBABLE CAUSE:**
1. Power OFF.
  2. Bad connector or incorrect wiring to control unit.
- CORRECTIVE ACTION:**
1. Turn power switch ON or connect power.
  2. Check for proper plug connections or repair / replace LCD display module.

**X. INSTRUMENT SETTINGS**

The top line of the LCD display is formatted to show a selected value along with its engineering units, and the second line normally provides function labels for the four pushbuttons located below the display. The pushbuttons do not have any labels, so for the purpose of this document, the pushbuttons will be assigned numbers 1 through 4.

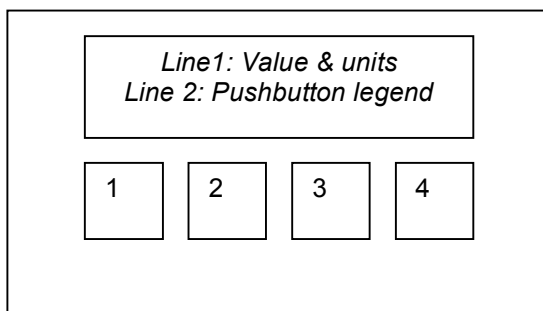

**MAIN RUN SCREEN**

The value displayed is the chlorine residual in ppm or mg/l. Below the residual value is a fifty segment bar-graph representation of the residual 4mA to 20mA output (PO1).

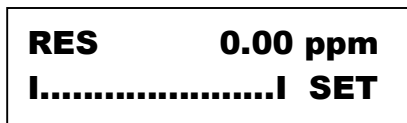

1	<i>no label</i>	Displays the water temperature.
4	SET	The user is prompted to enter a password to enter a programming mode in which one can calibrate, set alarm set-points, and set the 4-20mA output range.

## PASSWORD ENTRY SCREEN

From the run screen, press SET and the user will be prompted to enter the password (default is 000).

**ENTER PASSWORD**  
**0 0 0 ENT**

## AGITATOR MOTOR CONTROL

If the entered password is correct, the operator is given the choice of turning off the agitator motor prior to service. The following screen is displayed.

**STOP MOTOR?**  
**YES NO**

Enter selection by pressing key #3 or 4.

## RESIDUAL SETUP MENU

Once the motor control selection is made, the residual setup menu(calibration, alarm, & range) will be displayed.

**RESIDUAL SETUP**  
**CAL ALM RNGE RUN**

1	CAL	Enter calibration menu
2	ALM	Set the high and low residual alarm setpoints
3	RNG	Set the 4-20mA output range.
4	RUN	Go back to the main run screen

**CALIBRATE**  
**CELL        OUT    ESC**

1	CELL	Calibrate cell
2	No function	
3	OUT	Calibrate the 4-20mA output.
4	ESC	First, the operator is prompted to enter a new password and then is returned to the residual setup menu.

## CALIBRATE CELL SCREEN

From the residual setup screen, press CELL to enter the cell calibration menu.

<b>CALIBRATE CELL</b> <b>ZRO SPAN ESC</b>
--

1	ZRO	Zero cell input
2	SPAN	Set the current CL2 residual.
3	no function	
4	ESC	Go back to the calibrate menu.

## CALIBRATE ZERO SELECTION SCREEN

<b>CALIBRATE ZERO</b> <b>MAN AUTO ESC</b>
--

1	MAN	Manual zero
2	AUTO	Auto zero
3	no function	
4	ESC	Go back to the calibrate cell menu.

## MANUAL ZERO SCREEN

WAIT FOR...

<b>0.0 mV SET</b> <b>ESC</b>
---------------------------------

The top line of the display scrolls the message, "ADD ZERO WATER & WAIT FOR STABLE mV."  
The left side of the bottom line shows the current cell mV.

1	No function	
2	No function	
3	SET	Zero cell input.
4	ESC	Go back to the calibrate zero menu.

## AUTO ZERO SCREEN

**AUTO ZERO 120s**  
**0.0mV            ESC**

This screen will automatically zero the cell input if there is a stable mV input for 120 seconds. If the auto zero successful, the instrument will display an auto zero successful message. If fifteen minutes pass without an auto zero, the instrument will display an auto zero failure message.

The top, right side of the display shows a timer, and the bottom, left side shows the current cell mV.

1	No function	
2	No function	
3	No function	
4	ESC	Go back to the calibrate zero menu.

## CALIBRATE CELL SPAN SCREEN

**GET SAMPLE**  
**0.0 mV        STR ESC**

1	No function	
2	No function	
3	STR	Sample the cell input mV & water temperature and enter the screen where the CL <sub>2</sub> residual value can be set.
4	ESC	Go back to the calibrate cell menu.

If one attempts to set a ppm when the mV input is lower than the zeroed mV, the error message "ERROR! CELL mV <= ZERO" will be displayed for a few seconds.

**0.0ppm**  
**UP DWN SET ESC**

1	UP	Increase CL <sub>2</sub> value
2	DWN	Decrease CL <sub>2</sub> value
3	SET	The value entered is the CL <sub>2</sub> residual at the time the STR pushbutton was pressed.
4	ESC	Go back to the get sample screen

## CALIBRATING THE ANALOG OUTPUT

For one to calibrate the analog output, an accurate DMM or equivalent current meter (20mA range) must be connected alone or in series with the 4 to 20mA (P01) load.

<b>SET ANALOG OUT</b> <b>4mA 20mA ESC</b>
--

1	4mA	Set 4mA point
2	20mA	Set 20mA point
3	No function	
4	EXIT	Go back to the calibrate menu.

<b>SET XX.00mA OUT</b> <b>UP DWN ESC</b>
---

The XX.00 is either 4.00 or 20.00 and does not change when setting the selected point. Observe the current reading from the DMM and use the up and down pushbuttons to set the selected point to 4/20mA.

1	UP	Increase current
2	DWN	Decrease current
3	No function	
4	SET	Store new 4mA or 20mA point

## SETPOINTS

The 8000 has CL<sub>2</sub> residual high and low relay (alarm) outputs. Press ALM from the RESIDUAL SETUP screen. Select either the LOW or HIGH set point. Use the up & down pushbuttons to set the trip point and press set to store the new value. To disable a set point, enter a zero value. A low set point is activated when the CL<sub>2</sub> residual falls to or below the set point and is deactivated when the CL<sub>2</sub> residual rises above the trip set point plus a 0.10 (0.010) ppm(mg/l) hysteresis. A high set point is activated when the CL<sub>2</sub> residual rises to and above the high trip point and is deactivated when the CL<sub>2</sub> residual falls below the set point minus a 0.10 (0.010) ppm(mg/l) hysteresis.

When an alarm occurs, a message appears in the main run screen indicating the exact alarm. One now has two options:  
 IGNORE the alarm and de-energize the associated relay indefinitely.

CANCEL the alarm and de-energize the associated relay for 10 seconds and then reactivate the alarm if the situation has not been resolved.

<b>LOW</b>	<b>2.0 ppm</b>
<b>UP DWN</b>	<b>SET</b>

<b>HIGH</b>	<b>10.0 ppm</b>
<b>UP DWN</b>	<b>SET</b>

**CELL RANGE**

To set the range, press RNG in the residual setup screen. There are two ranges set by S2 which is located on the 8000 MAIN board.

<b>RNG FS</b>	<b>0-10.0 ppm</b>
<b>UP DWN</b>	<b>SET</b>

<b>RNG</b>	<b>S2 POSITION</b>	Scale the 4-20mA analog output
Value X.XX	A	0 to 1,2,3,5,10, and 20 value selections (use the up and down pushbuttons to select)
Value X.XXX	B	0 to 0.1, 0.2, 0.3, 0.5, 1, and 2 value selections (use the up and down pushbuttons to select)